

**SUBMERSIBLE
SLURRY PUMP**

DIVA PRO

SERIES 60HZ



Features

- Double mechanical seal SIC/SIC with SIC/SIC in oil bath
- Heavy-duty with agitator mode
- Protected with Yamada overload protector
- Top flange discharge with semi-circumferential cooling for continuous duty

Applications

Choice of industries that face the most difficult pumping applications

- Lime slurries
- Mill scale
- Coal runoff sumps
- Wash down sumps
- Mining
- Tunneling
- Quarries

Data Chart

Type	Output		Discharge	F.L.A.		Rated		Maximum		Free Passage	Weight(W/O Cable)
	HP	kW		3ø 230V	3ø 460V	Head FT	Cap. GPM	Head FT	Cap. GPM		
100(150)DIVA PRO-6.100	10	7.5	4"(6")	29A	14.5A	43	396	69	793	20	150
100(150)DIVA PRO-6.150	15	11	4"(6")	43A	21.5A	49	528	75	977	20	175
150(200)DIVA PRO-6.200	20	15	6"(8")	58A	29A	49	1057	75	1638	25	250
150(200)DIVA PRO-6.240	24	18	6"(8")	69A	34.5A	69	793	95	1400	25	360
150(200)DIVA PRO-6.300	30	22	6"(8")	86A	43A	66	1030	112	1374	25	390
200DIVA PRO-6.300L	30	22	8"	86A	43A	49	1321	85	1585	25	400

Specifications

Liquid Temperature	0~40°C (32~104°F)	
Submersible depth	20M	
Motor Part	Frequency	60Hz
	Pole	4 Pole
	Type	Dry Type
	Insulation	Class F
	Protection	IP 68
Pump Part	Protector	Auto-Cut
	Bearing	Ball Type
	Mechanical seal	Double Mechanical Seal
	Impeller	Semi-open Impeller

Performance Curve

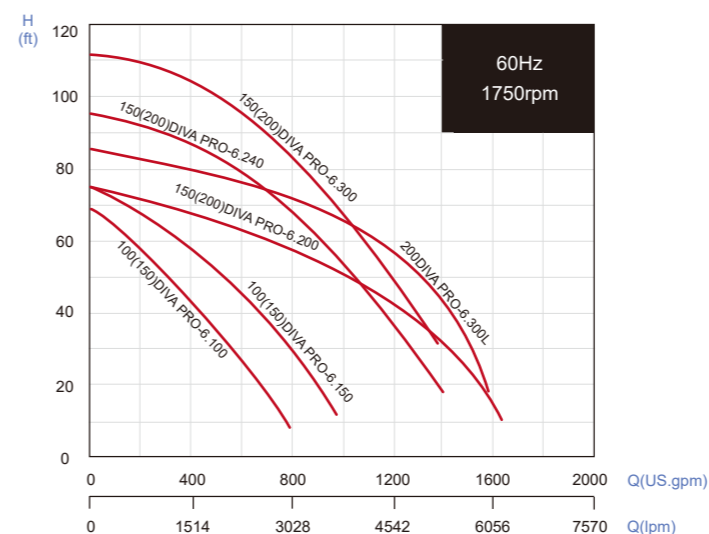

All technical information is subject to change without notice.



Semi-open Impeller



High Chrome Steel Impeller with Agitator

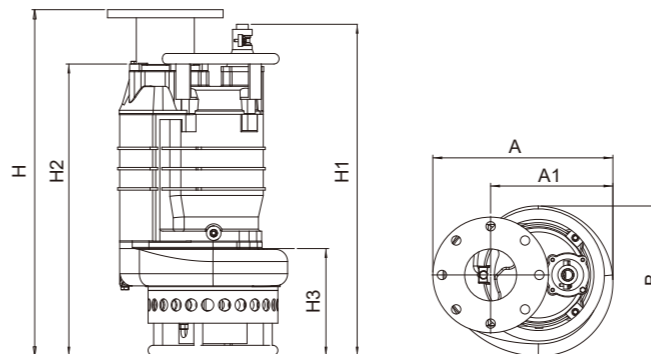

100(150)DIVA PRO-6.100~6.150

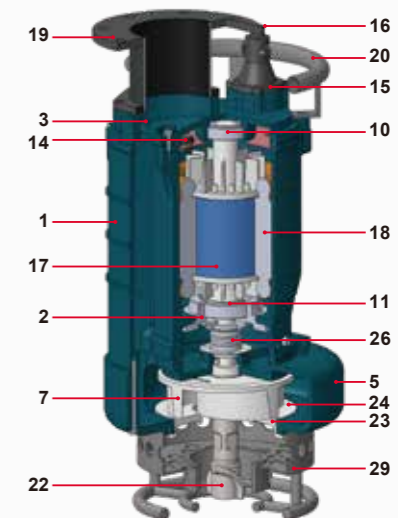

Parts and Material List

No.	Part	Material
1	Motor Frame	ASTM A48 Class 30
2	Bearing Bracket	ASTM A48 Class 30
3	Top Bracket	ASTM A48 Class 30
5	Pump Casing	ASTM A48 Class 30
7	Impeller	High Chrome Steel
10	Upper Bearing	NTN/TPI
11	Lower Bearing	NTN/TPI
14	Protector	YAMADA
15	Gland Holder	ASTM A48 Class 30
16	Cable Gland	BUNA N
17	Shaft with Rotor	10~15HP: AISI 410 20~30HP: AISI 420
18	Stator	
19	Discharge	SC
20	Handle	SC
23	Suction Plate	10~20HP: High Chrome Steel 30HP: ASTM A48 Class 30
24	Wearing Plate (30HP Only)	High Chrome Steel
26	Mechanical Seal	Upper:SIC/SIC ; Lower:SIC/SIC
29	Strainer	SC

TPI is a family brand of NTN group.

Dimensions (mm)

Type	A	A1	B	H	H1	H2	H3
100(150)DIVA PRO-6.100	445	305	380	855	820	720	265
100(150)DIVA PRO-6.150	445	305	380	855	820	720	265
150(200)DIVA PRO-6.200	520	350	425	1000	950	860	313
150(200)DIVA PRO-6.240	585	440	530	1160	1145	1010	330
150(200)DIVA PRO-6.300	585	440	530	1160	1145	1010	330
200DIVA PRO-6.300L	585	440	530	1160	1145	1010	330

