

LIGHTWEIGHT SUBMERSIBLE DEWATERING PUMP

EUB
EUBS AISI 304
EUBI AISI 316
SERIES 60HZ



Features

- High resistance to abrasive liquids
- Loss wax casting AISI 304 and AISI 316 for EUBS and EUBI
- Viton gasket, O-rings, and Lip seal for EUBI (AISI 316)
- Compact & Lightweight design
- Efficient circumferential cooling for continuous duty

Applications

- Site drainage, mining, tunneling, public works, floods
- Cement industry, river intake, civil engineering projects
- Version "S" in AISI 304 and "I" in AISI 316 are suitable for light chemical liquids in drainage and general pumping applications

Data Chart

Type	Output		Discharge	F.L.A.			Rated		Maximum		Free Passage	Weight(W/O Cable)	
	HP	kW		1ø	3ø	3ø	Head	Cap.	Head	Cap.		mm	1ø-kg
			Inch	230V	230V	460V	FT	GPM	FT	GPM			
50EUB-6.05	0.5	0.37	2"	3.3A	2.2A	1.1A	26	30	33	61	6	11.3	11.3
50EUBS(I)-6.05	0.5	0.37	2"	3.3A	2.2A	1.1A	26	30	33	61	6	14.1(13.8)	14.1(13.8)
50EUB-6.10	1	0.75	2"	6A	4A	2A	33	55	62.4	82	6	13.7	13.7
50EUBS(I)-6.10	1	0.75	2"	6A	4A	2A	33	55	62.4	82	6	17.2(16.7)	17.2(16.7)
50(80)EUB-6.20	2	1.5	2"(3")	14A	8A	4A	43	70	62.5	132	6	21.1	21.1
50(80)EUBS-6.20	2	1.5	2"(3")	13A	8A	4A	43	80	62.5	153	6	25	25

» Float switch is optional for above pump in single phase.

Specifications

Liquid Temperature	0~40°C (32~104°F)	
Submersible depth	10M	
Motor Part	Frequency	60Hz
	Pole	2 Pole
	Type	Dry Type
	Insulation	Class B
	Protection	IP 68
	Protector	Auto-cut
Pump Part	Bearing	Ball Type
	Mechanical seal	Double Mechanical Seal
	Impeller	Semi-Open Impeller

Performance Curve

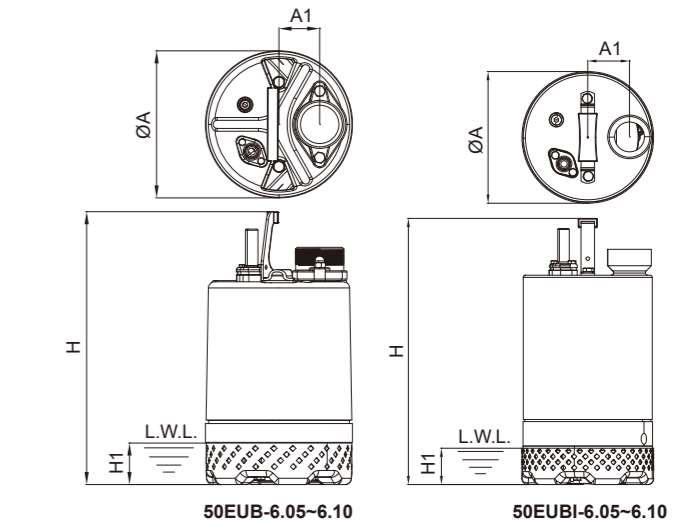
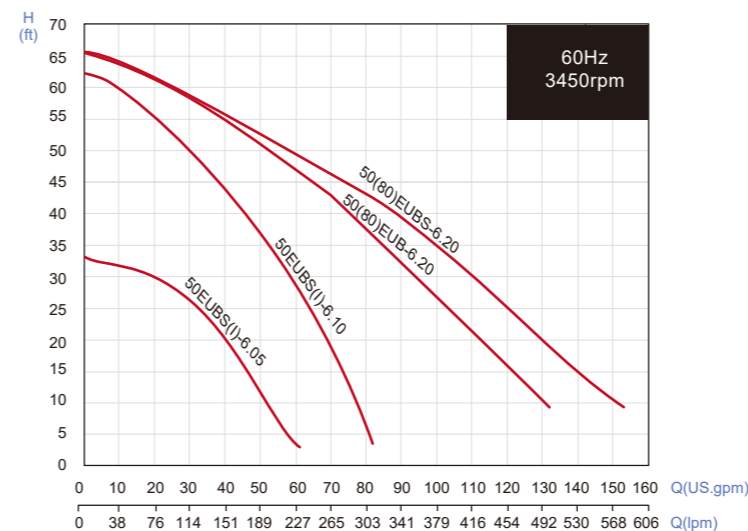

Dimensions (mm)

Type	A	A1	H	H1
50EUB-6.05	188	52	345	53
50EUBS(I)-6.05	188(184)	52	345	52
50EUB-6.10	188	52	370	53
50EUBS(I)-6.10	188(184)	52	370	52
50(80)EUB-6.20	225	52	474	81
50(80)EUBS-6.20	225	52	455	81

KLIXON

KLIXON protector provides protection against overheating from all running and stalled rotor conditions including:

- Plugging duty
- Stalling or failure to start
- Heavy overloads
- High ambient
- Ventilation failures



KLIXON
1PH Protector (Thermal)



KLIXON
1PH Protector (optional) (overheat & overload)



KLIXON
3PH Protector (overheat, overload, phase failure)



DU PONT Hytrel®
Steel coated with thermoplastic polyester elastomer



Loss Wax Stainless Steel AISI 304 & 316 EUBS(I) Impeller



Viton gasket, O-rings, and Lip seal for EUBI (AISI 316)

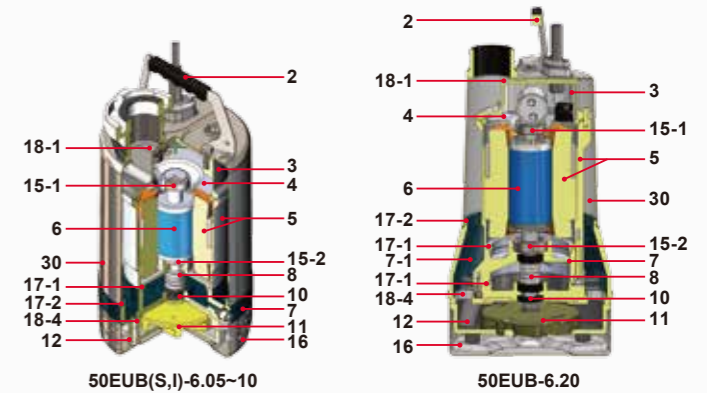

Parts and Material List

No.	Part	Material			
		EUB (0.5~1HP)	EUB (2HP)	EUBS	EUBI
2	Handle	Steel+BUNA N	Steel+BUNA N	AISI 304+BUNA N	AISI 304+BUNA N
3	Motor Cover	ADC12	ADC12	AISI 304	AISI 316
4	Bracket	Steel	Steel	ASTM A48 Class 30	ASTM A48 Class 30
5	Motor Housing + Stator	ADC12+Steel	ADC12+Steel	AISI 304	AISI 316
6	Shaft with Rotor	AISI 410	AISI 410	AISI 304	AISI 316
7	Oil Chamber	ADC12	ASTM A356	AISI 304	AISI 316
7-1	Oil Chamber	-	ASTM A356	-	-
8	Mechanical Seal	CA/CE+SIC/SIC			
10	Lip Seal	BUNA N	BUNA N	BUNA N	VITON
11	Impeller	Hytrel	Hytrel	AISI 304	AISI 316
12	Pump Casing	ASTM A48 Class 30	ASTM A48 Class 30	AISI 304	AISI 316
15-1	Upper Bearing	NTN/TPI			
15-2	Lower Bearing	NTN/TPI			
16	Strainer	AISI 304	AISI 304	AISI 304	AISI 316
17-1	O-ring	BUNA N	BUNA N	BUNA N	VITON
17-2	O-ring	BUNA N	BUNA N	BUNA N	VITON
18-1	Gasket	BUNA N	BUNA N	EPDM	VITON
18-4	Volute Liner	BUNA N	BUNA N	EPDM	EPDM
30	Outer Housing	AISI 304	AISI 304	AISI 304	AISI 316

TPI is a family brand of NTN group.