

## LIGHTWEIGHT SUBMERSIBLE DEWATERING PUMP FOR SLUDGE / SOLIDS HANDLING

# EUBL

### SERIES 60HZ



### Features

- High abrasive resistance to liquids containing sand and gravel
- Free passage to 38mm in diameter
- Lightweight
- Pump body is highly resistant to impact
- Quick & easy replacement of wear components
- Air vent mechanism built-in allowing water to cool the motor when pumping
- Efficient circumferential cooling for continuous duty

### Applications

- Construction and industrial sites
- Tunneling, public works, floods
- Emergency situation

### Data Chart

Type	Output		Discharge	F.L.A.			Rated		Maximum		Free Passage	Weight(W/O Cable)		Q.D.C.
	HP	KW		1ø	3ø	3ø	Head	Cap.	Head	Cap.		mm	1ø-kg	
50EUBL-6.10			Inch	230V	230V	460V	Head	Cap.	Head	Cap.	38	14	14	-
	1	0.75	2"	6A	4A	2A	31	35	46	90				

### Specifications

Liquid Temperature		0~40°C (32~104°F)
Submersible depth		10M
Motor Part	Frequency	60Hz
	Pole	2 Pole
	Type	Dry Type
	Insulation	Class B
Pump Part	Protection	IP 68
	Protector	Auto-cut
	Bearing	Ball Type
	Mechanical seal	Double Mechanical Seal
Impeller		Semi-open Impeller



**KLIXON**  
1PH Protector  
(Thermal)



**KLIXON**  
1PH Protector  
(optional)  
(overheat & overload)



**KLIXON**  
3PH Protector  
(overheat, overload,  
phase failure)



**DU PONT Hytrel®**  
Steel coated with  
thermoplastic  
polyester elastomer

## KLIXON

KLIXON protector provides protection against overheating from all running and stalled rotor conditions including:

- Plugging duty
- Stalling or failure to start
- Heavy overloads
- High ambient
- Ventilation failures

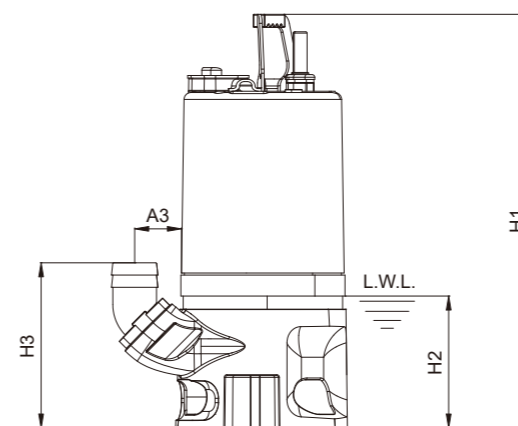
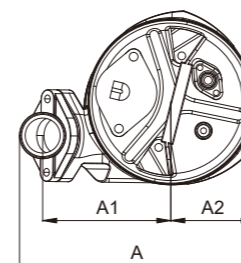

### Dimensions (mm)

Type	A	A1	A2	A3	H1	H2	H3
50EUBL-6.10	270	152	96	54	475	151	191

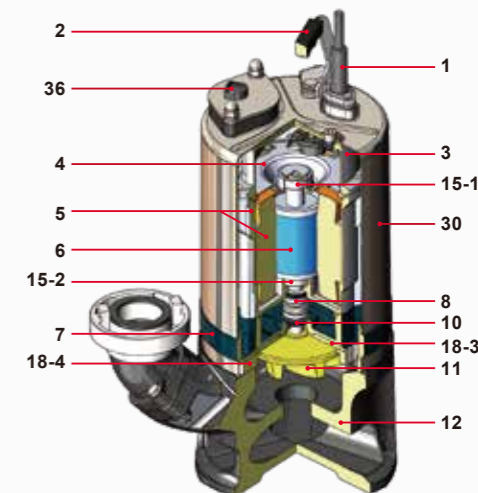

### Parts and Material List

No.	Part	Material
1	Cable	H07RN-F /SJTOW/STOW
2	Handle	Steel + BUNA N
3	Motor Cover	ADC 12
4	Upper Bearing Bracket	Steel
5	Motor Housing + Stator	ADC 12 / Steel
6	Shaft with Rotor	AISI 410
7	Oil Chamber	ADC 12
8	Mechanical Seal	CA/CE + SIC/SIC
10	Lip Seal	BUNA N
11	Impeller	Hytrel
12	Pump Casing	Hytrel
15-1	Upper Bearing	NTN/TPI
15-2	Lower Bearing	NTN/TPI
18-3	Wearing Plate	PA 66 Plastic
18-4	Volute Liner	BUNA N
30	Outer casing	AISI 304
36	Air Exhauste	BUNA N / AISI 304

TPI is a family brand of NTN group.

### Performance Curve

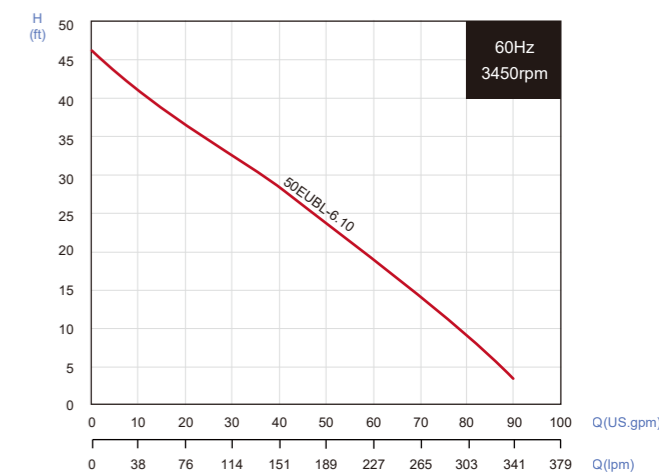

All technical information is subject to change without notice.