

LIGHTWEIGHT SUBMERSIBLE DEWATERING PUMP FOR SLUDGE / SOLIDS HANDLING

EUBL SERIES 50HZ



Features

- High abrasive resistance to liquids containing sand and gravel
- Free passage to 38mm in diameter
- Lightweight
- Pump body is highly resistant to impact
- Quick & easy replacement of wear components
- Air vent mechanism built-in allowing water to cool the motor when pumping
- Efficient circumferential cooling for continuous duty

Applications

- Construction and industrial sites
- Tunneling, public works, floods
- Emergency situation

Data Chart

Type	Output		Discharge	F.L.A.		Rated		Maximum		Free Passage	Weight(W/O Cable)		Q.D.C.
	HP	KW		1Ø	3Ø	Head	Cap.	Head	Cap.		1Ø-kg	3Ø-kg	
50EUBL-5.10			Inch	1Ø	3Ø	Head	Cap.	Head	Cap.	mm	1Ø-kg	3Ø-kg	
				230V	400V	M	LPM	M	LPM				
	1	0.75	2"	5.8A	2A	8	170	12	380	38	14	14	-

Specifications

	Liquid Temperature	0~40°C (32~104°F)
	Submersible depth	10M
Motor Part	Frequency	50Hz
	Pole	2 Pole
	Type	Dry Type
	Insulation	Class B
Pump Part	Protection	IP 68
	Protector	Auto-cut
	Bearing	Ball Type
	Mechanical seal	Double Mechanical Seal
	Impeller	Semi-open Impeller

KLIXON

KLIXON protector provides protection against overheating from all running and stalled rotor conditions including:

- Plugging duty
- Stalling or failure to start
- Heavy overloads
- High ambient
- Ventilation failures



KLIXON
1PH Protector (Thermal)



KLIXON
1PH Protector (optional) (overheat & overload)



KLIXON
3PH Protector (overheat, overload, phase failure)



DU PONT Hytrel®
Steel coated with thermoplastic polyester elastomer

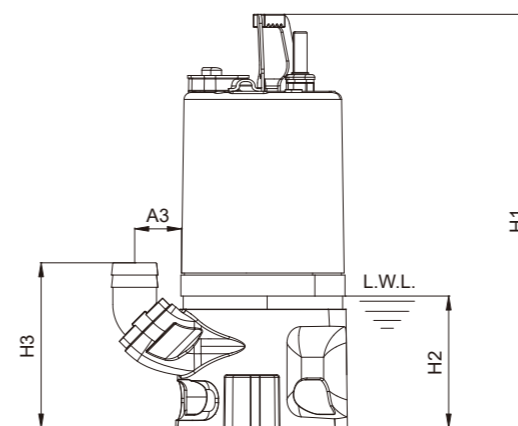
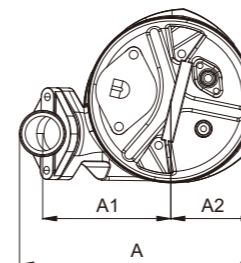

Dimensions (mm)

Type	A	A1	A2	A3	H1	H2	H3
50EUBL-5.10	270	152	96	54	475	151	191

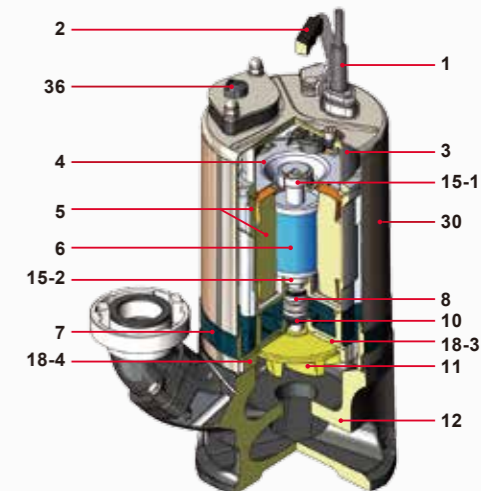

Parts and Material List

No.	Part	Material
1	Cable	H07RN-F
2	Handle	Steel + NBR
3	Motor Cover	ADC 12
4	Upper Bearing Bracket	Steel
5	Motor Housing + Stator	ADC 12 / Steel
6	Shaft with Rotor	AISI 410
7	Oil Chamber	ADC 12
8	Mechanical Seal	CA/CE + SIC/SIC
10	Lip Seal	NBR
11	Impeller	Hytrel
12	Pump Casing	Hytrel
15-1	Upper Bearing	NTN/TPI
15-2	Lower Bearing	NTN/TPI
18-3	Wearing Plate	PA 66 Plastic
18-4	Volute Liner	NBR
30	Outer casing	AISI 304
36	Air Exhauste	NBR / AISI 304

TPI is a family brand of NTN group.

Performance Curve

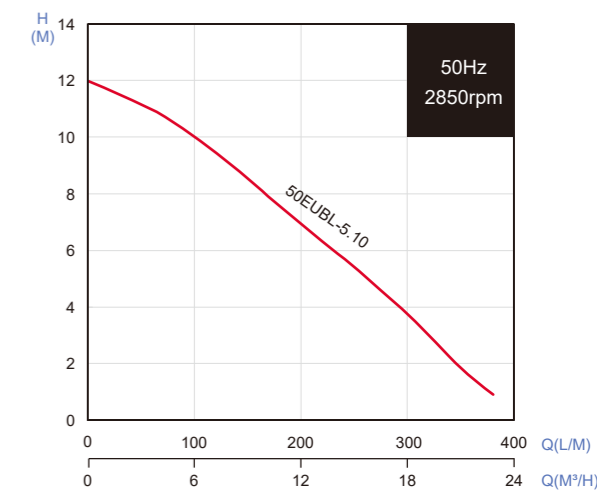

All technical information is subject to change without notice.